

# Thwaites MACH 581

SPECIFICATIONS

## 3 Tonne Front Tip Hydrostatic

MACH581

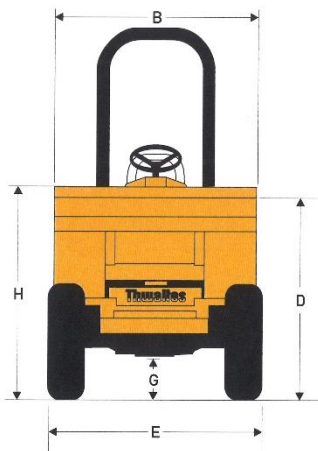
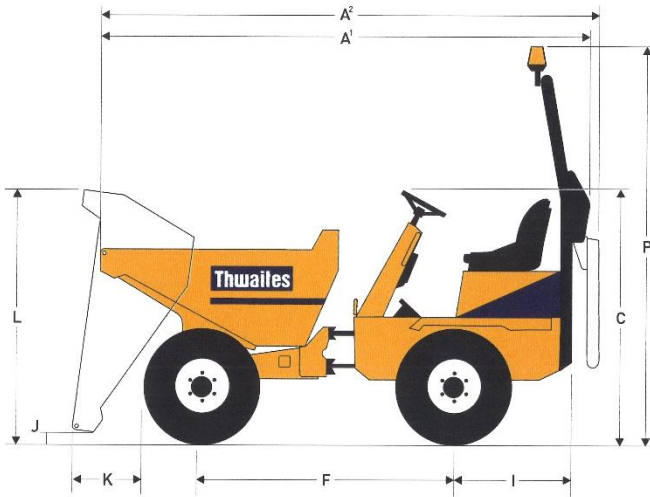

**Dimensions (mm)**

A <sup>1</sup>	3774
A <sup>2</sup>	3939
B	1650
C	1965
D	1365
E	1650
F	1950
G	330
H	1508
I	1032
J	305
K	615
L	2115
P	3092

<b>Capacities</b>	Max safe load	3000 kg
	Heaped	1680 litres
	Struck	1350 litres
	Water	1060 litres

**Engine**

Yanmar 3TNV88, 24.8 kW/33.2 bhp (nett) at 2800 rpm, 3-cylinder water-cooled direct-injection diesel. Max. torque 111 Nm (82 lbf ft). Electric starting, hour meter, battery isolator switch and heavy-duty cyclonic air cleaner positioned within the lockable engine compartment.

**Noise Levels**

Operator's ear 84 LpA, airborne sound power level 101 LwA (to 2000/14/EC).

**Transmission**

Hydrostatic with high/low speed range and forward/reverse direction controlled by one column-mounted lever. Inching facility for precise manoeuvres in restricted areas activated by first push on brake pedal.

**Speeds**

Forward and reverse	Low	0-8.0 km/h ( 4.9 mph)
	High	0-21.1 km/h (13.1 mph)

**Tyres**

295/80 x 15.3  
Load/Speed Index 119 A8  
Track grip tread

**Brakes and Axles**

Totally enclosed multiplate oil-immersed discs mounted on rear axle effective on all four wheels. Automatic adjustment for wear. Hand-operated parking brake. Heavy-duty axles with epicyclic reduction and fully floating halfshafts. Reduction gearbox integral with rear axle differential housing.

**Kinglink Chassis**

Front and rear chassis constructed from deep section folded steel plate, with three-point Kinglink giving centre articulation and oscillation for better stability, traction and extra safety on site. Remote greasing point provided for lubrication of top Kinglink articulation pin.

**Skip**

Hydraulically operated, 5 mm steel plate all round, fully welded, mouth and sides of skip reinforced with box sections giving greater strength to minimise skip damage. No material traps.

<b>Shipping Cube</b>	12.5 m <sup>3</sup> (with folded ROPS)
----------------------	--

<b>Unladen Weight</b>	2060 kg
-----------------------	---------

<b>Clearance Diameter</b>	9.2 m
---------------------------	-------

<b>Towing Bracket</b>	Standard
-----------------------	----------

**ROPS**

For the UK and other markets where it is a legal requirement a fully approved folding ROPS frame is fitted as standard.

**Optional Extras**

Beacon. Full road lighting equipment. UK road equipment. Anti-theft device.

**Seating & Controls**

Adjustable suspension seat, accessible from both sides. Audible warning device at key start 'on' position. Super-bright warning lights for all critical functions. Electric horn. Large pedal pads with handbrake and hydraulic controls ready to hand.

**Service Access**

Lockable 3-sided cover opens to provide easy access from ground level to engine service points, all located on the same side. Moulded diesel and hydraulic tanks positioned low in the chassis side members, permitting access to the filler caps from ground level.

**Electrics**

Wiring harness contained within conduits and all electrical components water resistant to IP65/67 standards.

**Steering and Hydraulics**

Hydraulic priority power steering. Filter mounted on the top of the tank accessible from ground level. Combined suction and return filtration for all services. Hydraulic test points fitted as standard.

<b>Tank Capacities</b>	Fuel	24.5 litres
	Hydraulic	25.0 litres